

Air Conditioning
Technical Data

FDXM-F9

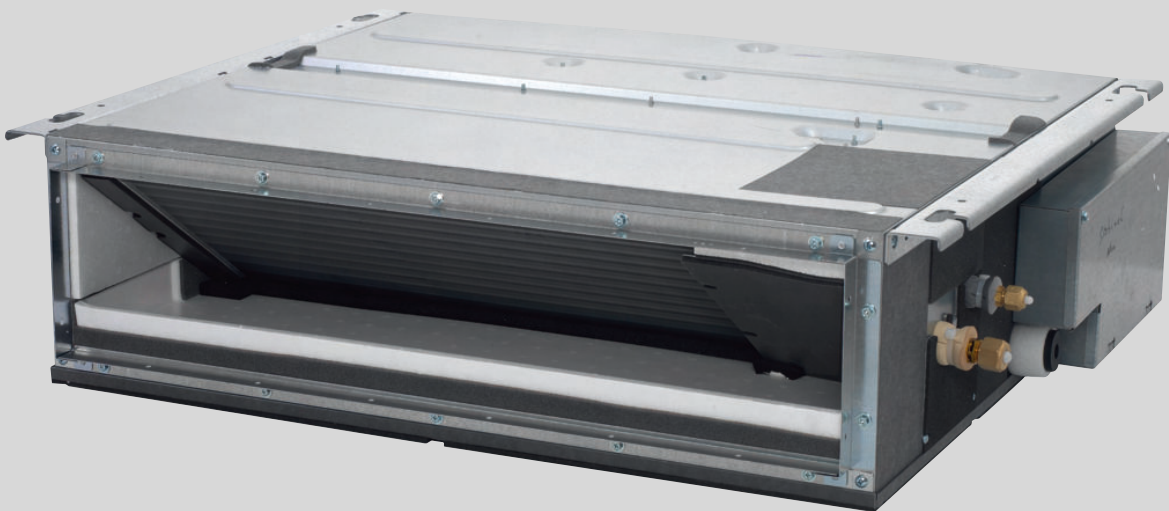

- > FDXM25F3V1B9
- > FDXM35F3V1B9
- > FDXM50F3V1B9
- > FDXM60F3V1B9

TABLE OF CONTENTS

FDXM-F9

1	Features	2
2	Specifications	3
	Technical Specifications	3
	Electrical Specifications	4
3	Safety device settings.....	5
4	Options.....	6
5	Dimensional drawings	7
6	Centre of gravity	8
7	Piping diagrams	10
8	Wiring diagrams	11
	Wiring Diagrams - Single Phase	11
9	Sound data	12
	Sound Pressure Spectrum	12
10	Fan characteristics	14

1 Features

Compact concealed ceiling unit, with a height of only 200mm

- Invisible unit as the unit is concealed in the ceiling: only the suction and discharge grilles are visible
- Compact dimensions, can easily be mounted in a ceiling void of only 240mm
- Medium external static pressure up to 40Pa facilitates unit use with flexible ducts of varying lengths
- Unified indoor unit range for R-32 and R-410A
- Auto cleaning filter option ensures maximum efficiency, comfort and reliability by regular filter cleaning
- Multi zoning kit allows multiple individually-controlled climate zones to be served by one indoor unit
- Online controller (optional): control your indoor from any location with an app, via your local network or internet and keep an overview on your energy consumption
- Low energy consumption thanks to DC fan motor

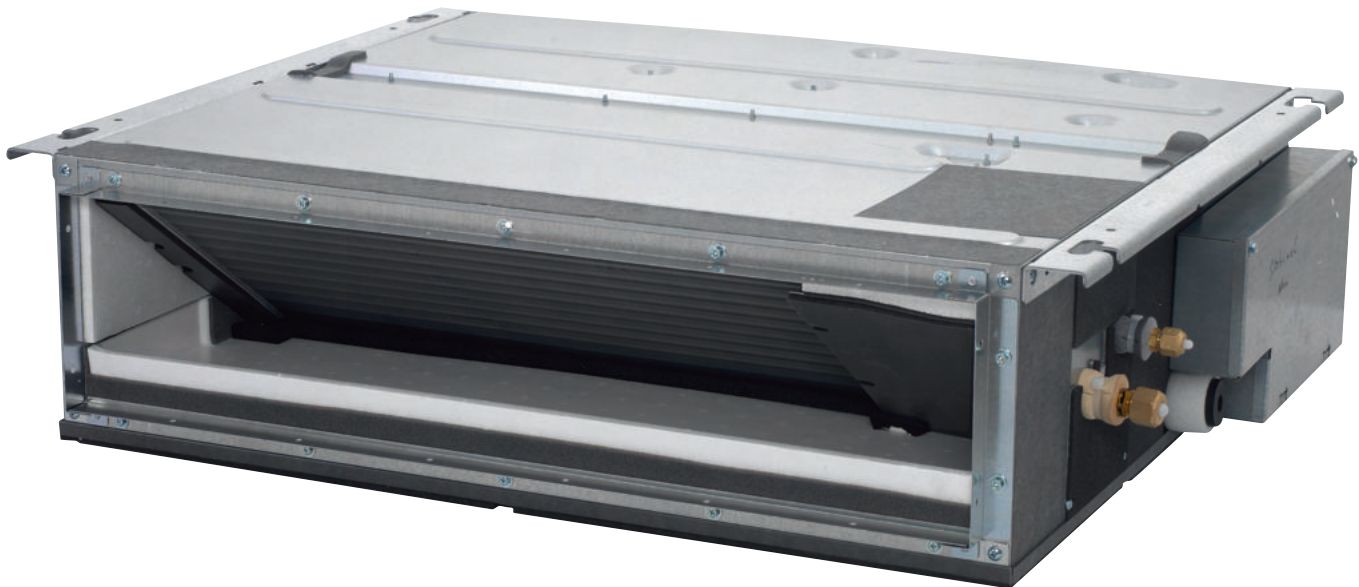

Auto-cleaning filter



Multi zoning



Fan only



Fan speed steps



Dry programme



Air filter



Weekly timer



24 hour timer



Infrared remote control



Wired remote control



Centralised control



Online controller via app



Auto-restart



Self diagnosis



Multi model application

2 Specifications

2-1 Technical Specifications				FDXM25F9	FDXM35F9	FDXM50F9	FDXM60F9	
Power input	Cooling	Nom.	kW	0.036		0.060		
	Heating	Nom.	kW	0.036		0.060		
Dimensions	Unit	Height/Width/Depth	mm	200/750/620		200/1,150/620		
	Packed unit	Height/Width/Depth	mm	266/922/768		266/1,322/768		
Weight	Unit		kg	21		28		
	Packed unit		kg	24		31		
Heat exchanger	Length		mm	500		900		
	Rows	Quantity		3		2		
	Fin pitch		mm	1.50				
	Stages	Quantity		12				
	Passes	Quantity		2.0		5.0		
	Tube type			ø7 Hi-XD				
	Fin	Type		Multi slit fin				
Air filter	Type			Removable / washable				
Fan	Type			Sirocco fan				
	Air flow rate	Cooling	High	m³/min	8.7		15.8	16.0
				cfm	307		558	565
			Medium	m³/min	8.0 (1)		14.6 (1)	14.8 (1)
				cfm	282		516	523
			Low	m³/min	7.3		13.3	13.5
				cfm	258		467	477
		Heating	High	m³/min	8.7		15.8	16.0
				cfm	307		558	565
			Medium	m³/min	8.0 (1)		14.6 (1)	14.8 (1)
				cfm	282		516	523
			Low	m³/min	7.3		13.3	13.5
				cfm	258		467	477
	External static pressure	Nom.	Pa	30		40		
Fan motor	Model			KFD-280-44-8A		KFD-280-65-8A		
	Speed	Steps		3				
		Cooling	High/Medium/Low	rpm	1,270/1,180/1,090		1,270/1,150/1,030	1,280/1,160/1,040
			Heating	High/Medium/Low	rpm	1,270/1,180/1,090		1,270/1,150/1,030
Sound power level	Cooling		dBA	53.0		55.0	56.0	
Sound pressure level	Cooling	High/Medium/Low	dBA	35.0/33.0 (1)/27.0		38.0/35.0 (1)/30.0		
	Heating	High/Medium/Low	dBA	35.0/33.0/27.0		38.0/35.0/30.0		
Refrigerant	Type			R-32 / R-410A				
Piping connections	Liquid	OD		6,35				
	Gas	OD		9.50		12.70		
	Drain			VP20 (I.D. 20/O.D. 26)				
	Heat insulation			Both liquid and gas pipes				
Temperature control				Microcomputer control				

Standard Accessories : Installation manual; Quantity : 1;

Standard Accessories : Operation manual; Quantity : 1;

Standard Accessories : Insulation for fitting; Quantity : 1;

Standard Accessories : Sealing pad; Quantity : 1;

Standard Accessories : Clamp metal; Quantity : 1;

Standard Accessories : Drain hose; Quantity : 1;

Standard Accessories : Washer for hanger bracket; Quantity : 8;

Standard Accessories : Sealing material; Quantity : 2;

Standard Accessories : Clamps; Quantity : 6;

2 Specifications

Standard Accessories : Washer fixing plate; Quantity : 4;

Standard Accessories : Screws for duct flanges; Quantity : 1;

Standard Accessories : Air filter; Quantity : 1;

2

2-2 Electrical Specifications		FDXM25F9	FDXM35F9	FDXM50F9	FDXM60F9
Power supply	Phase	1~			
	Frequency	Hz	50		
	Voltage	V	220-240		

Notes

(1) See separate drawing for electrical data

3 Safety device settings

3 - 1 Safety Device Settings

FDXM-F9

Safety devices		FDXM25-60F3V1B(9)
PCB fuse		250V, 3.15A
Fan motor overcurrent protection	Nominal	1.3A
Fan motor thermal protector	Maximum	125°C

4D110742

4 Options

4 - 1 Options

4

FDXM-F9

Option kit	Product name			
	FDXM25F3V1B	FDXM35F3V1B	FDXM50F3V1B	FDXM60F3V1B
Wired remote control	BRC1D52/BRC1D61 BRC1E53A7 ⁽¹⁾⁽⁴⁾ /BRC1E53B7 ⁽²⁾⁽⁴⁾ /BRC1E53C7 ⁽³⁾⁽⁴⁾			
Simplified remote control	BRC2E52C7 ⁽⁵⁾			
Stylish remote control				
Remote control for hotel use	BRC3E52C7 ⁽⁵⁾			
Wireless remote control	BRC4C65			
Central remote control	DCS302CA51/DCS302CA61 ⁽⁸⁾			
Unified ON/OFF controller	DCS301BA51/DCS301BA61 ⁽⁸⁾			
Schedule timer	DST301BA51/DST301BA61 ⁽⁸⁾			
Residential central remote control	DCS303A51 ⁽⁸⁾			
Adaptor for wiring	KRP1B56 ⁽⁶⁾			
Wiring adaptor for electrical appendices 1	KRP2A53 ⁽⁶⁾			
Wiring adaptor for electrical appendices 2	KRP4A54 ⁽⁶⁾			
Remote sensor	KRCS01-4B			
Installation box for adaptor PCB	KRP1BA101			
Electrical box with earth terminal (2 blocks)	KJB212AA			
Electrical box with earth terminal (3 blocks)	KJB311AA			
Noise filter (for electromagnetic interface only)	KEK26-1A			
Insulation kit for high humidity	KDT25N32/KDT25N50/KDT25N63			
Digital input adaptor	BRP7A54 ⁽⁶⁾⁽⁷⁾			
Auto cleaning filter - Small	BAE20A62	BAE20A62	-	-
Auto cleaning filter - Large	-	-	BAE20A102	BAE20A102

(1) Included languages are: English, German, French, Italian, Spanish, Portuguese, and Dutch.

(2) Included languages are: English, Czech, Croatian, Hungarian, Slovenian, Romanian, and Bulgarian.

(3) Included languages are: English, Russian, Greek, Turkish, Polish, Albanian, and Slovak.

(4) Includes duty rotation functionality

(5) Included languages are:

Language pack 1: English, German, French, Dutch, Spanish, Italian, and Portuguese.

With PC cable EKPCAB3 in combination with the Updater PC software, you can additionally change the language to:

Language pack 2: English, Bulgarian, Croatian, Czech, Hungarian, Romanian, and Slovenian.

Language pack 3: English, Greek, Polish, Russian, Serbian, Slovak, and Turkish.

(6) Requires installation box 6.

(7) Only possible in combination with simplified remote control BRC2/3E52C7.

(8) For Daikin Middle East only.

(9) For residential use only. Cannot be used with other centralised control equipment.

3D110004

5 Dimensional drawings

5 - 1 Dimensional Drawings

FDXM25-35F9

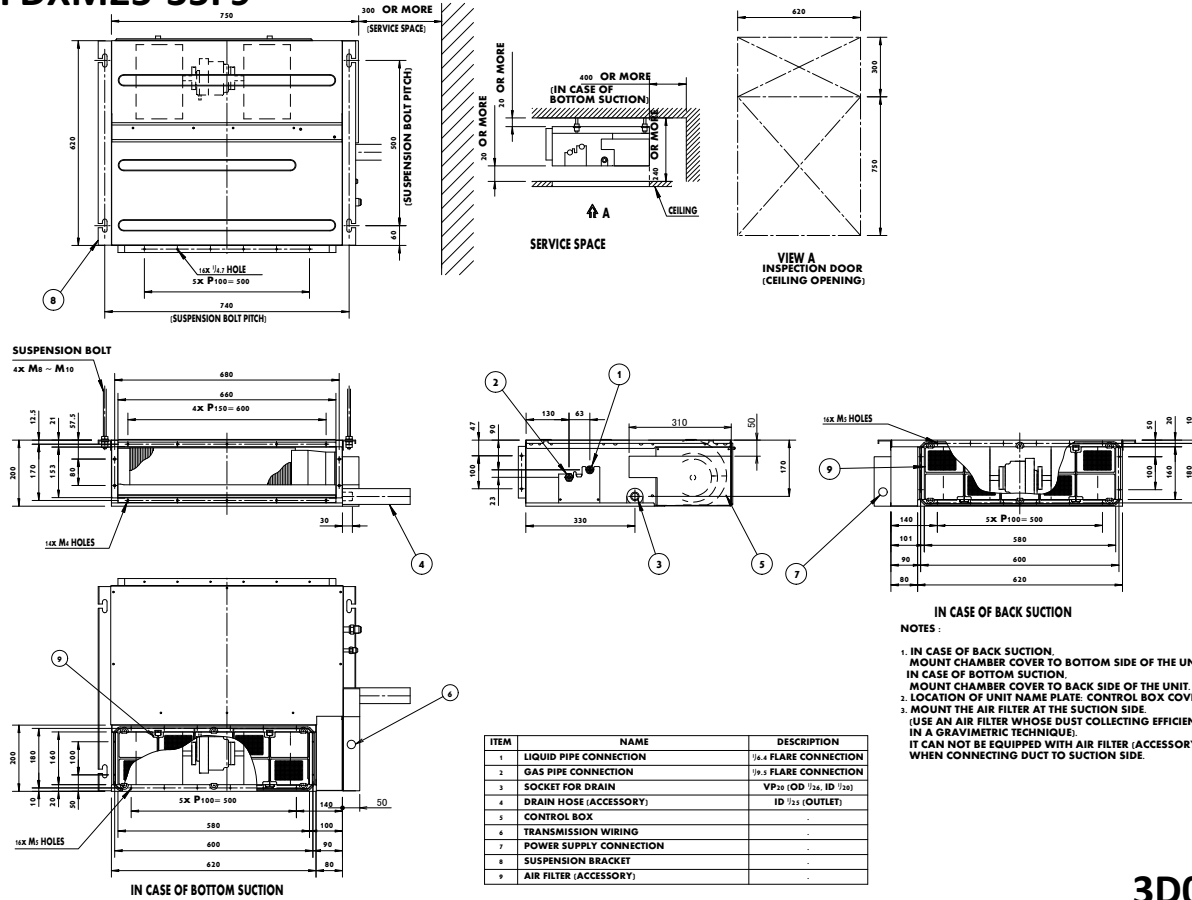

3D081343

FDXM50-60F9

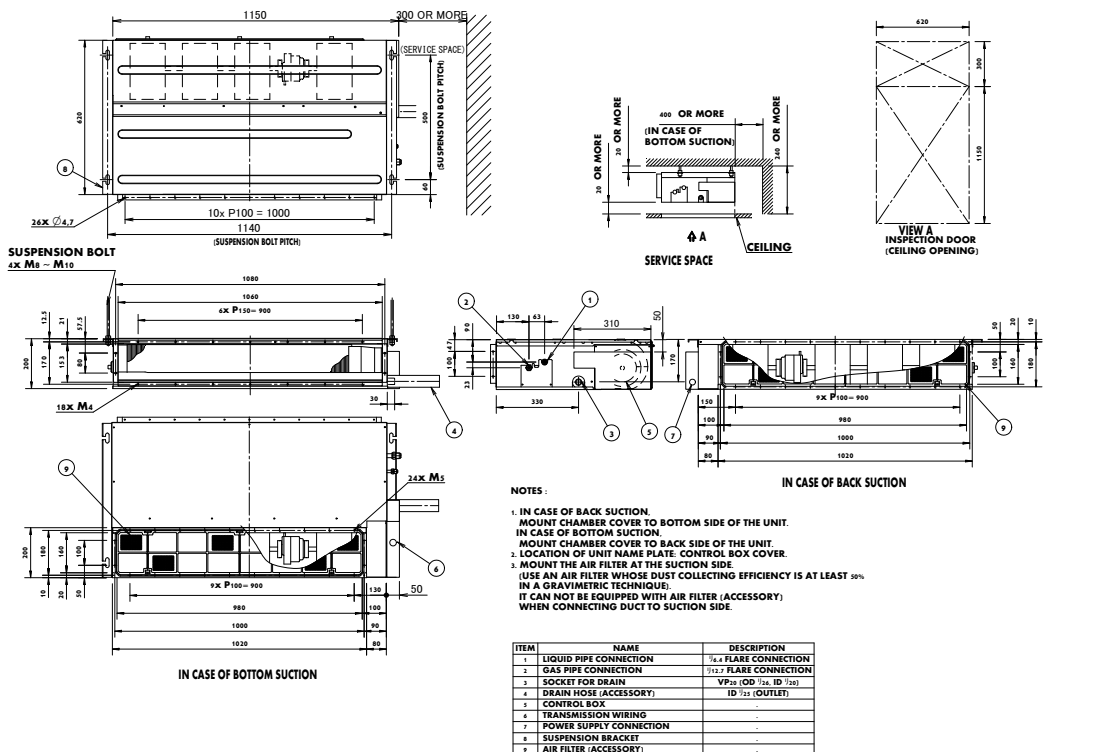

3D081360

6 Centre of gravity

6 - 1 Centre of Gravity

FDXM25-35F9

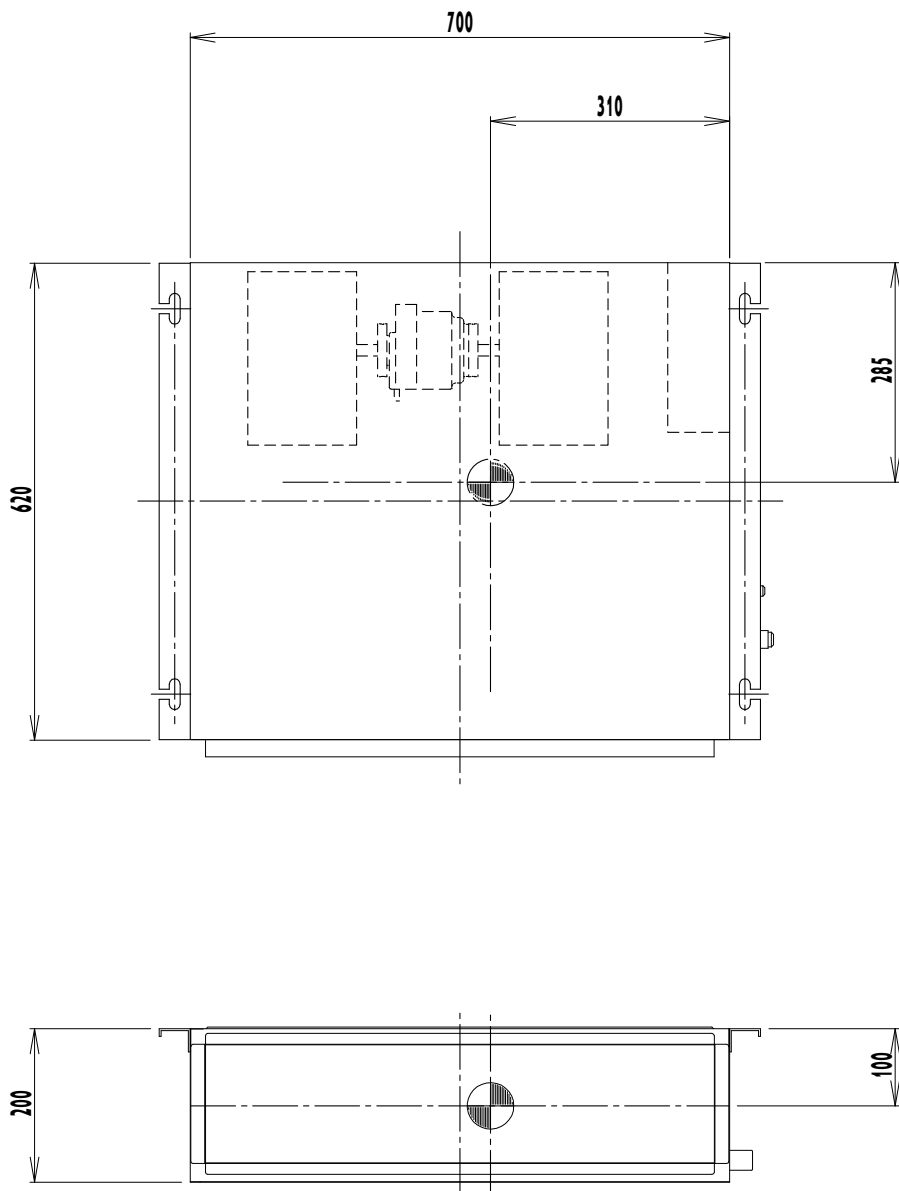

4D081337A

6 Centre of gravity

6 - 1 Centre of Gravity

FDXM50-60F9

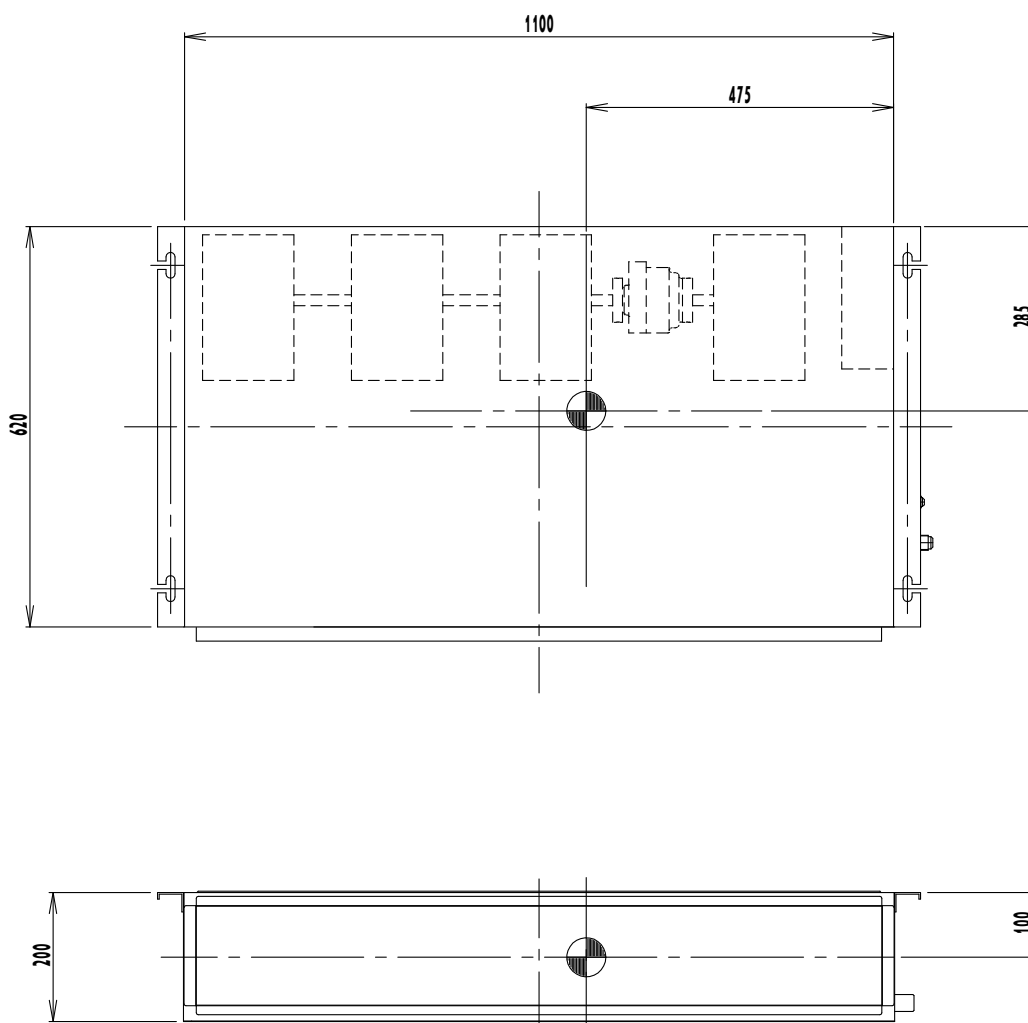

4D081339A

7 Piping diagrams

7 - 1 Piping Diagrams

FDXM-F9

Refrigerant flow
 —> Cooling
 - - -> Heating

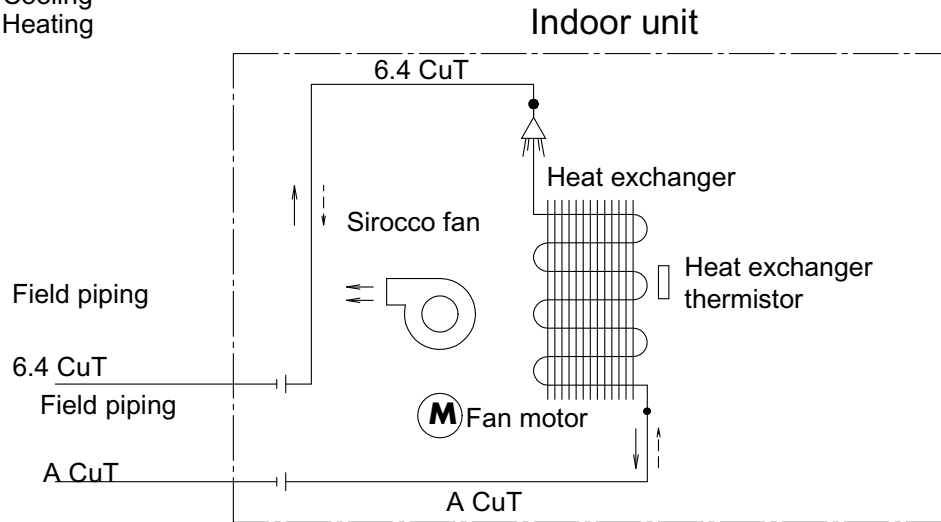

	A
FDXS₂₅F₂VEB	9.5
FDXS₃₅F₂VEB	
FNQ₂₅A₂VEB	
FNQ₃₅A₂VEB	
FDXM₂₅F₂V₁B	
FDXM₂₅F₃V₁B₉	
FDXM₃₅F₂V₁B	
FDXM₂₅F₃V₁B	
FDXM₃₅F₃V₁B	
FDXM₃₅F₃V₁B₉	
FDXS₅₀F₂VEB	12.7
FDXS₆₀F₂VEB	
FDXS₅₀F₂VEB₉	
FNQ₅₀A₂VEB	
FNQ₆₀A₂VEB	
FDXM₅₀F₂V₁B	
FDXM₅₀F₃V₁B₉	
FDXM₆₀F₂VEB	
FDXM₅₀F₃V₁B	
FDXM₆₀F₃V₁B	
FDXM₆₀F₃V₁B₉	

4D081335F

8 Wiring diagrams

8 - 1 Wiring Diagrams - Single Phase

FDXM-F9

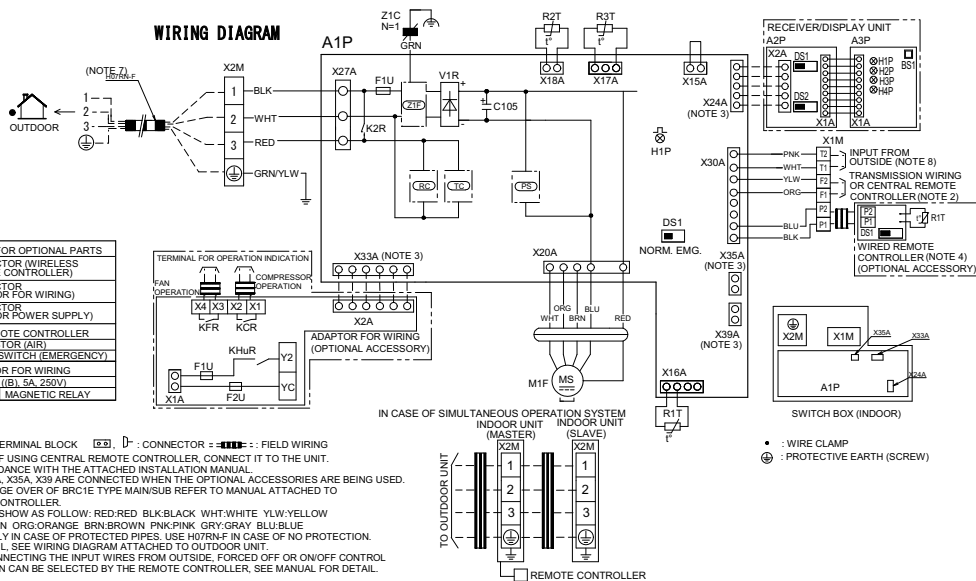

INDOOR UNIT		CONNECTOR FOR OPTIONAL PARTS	
A1P	PRINTED CIRCUIT BOARD	X24A	CONNECTOR (WIRELESS REMOTE CONTROLLERS)
C105	CAPACITOR	X33A	CONNECTOR (ADAPTOR FOR WIRING)
F1U	FUSE (F, 3.15A, 250V)	X35A	CONNECTOR (ADAPTOR POWER SUPPLY)
K2R	MAGNETIC RELAY	WIRED REMOTE CONTROLLER	
PCB	POWER SUPPLY CIRCUIT	R1T	THERMISTOR (AIR)
RC	RECEIVING CIRCUIT	DS1	SELECT SWITCH (EMERGENCY)
TC	TRANSMISSION CIRCUIT	ADAPTOR FOR WIRING	
H1P	LIGHT EMITTING DIODE (SERVICE MONITOR-GREEN)	F1U, F2U	FUSE (B, 5A, 250V)
M1F	MOTOR (FAN)	KFR, KCR, KHuR	MAGNETIC RELAY
R1T	THERMISTOR (AIR)		
R2T, R3T	THERMISTOR (COIL)		
DS1	SELECTOR SWITCH (EMERGENCY)		
V1F	DIODE BRIDGE		
X1M	TERMINAL STRIP (CONTROL)		
X2M	TERMINAL STRIP (POWER SUPPLY)		
Z1F	FERRITE CORE (NOISE FILTER)		
Z1F	NOISE FILTER		
RECEIVER/DISPLAY UNIT			
A2P	PRINTED CIRCUIT BOARD		
A3P	PRINTED CIRCUIT BOARD		
H1P	LIGHT EMITTING DIODE (ON-RED)		
H2P	LIGHT EMITTING DIODE (FILTER SIGN-RED)		
H3P	LIGHT EMITTING DIODE (TIMER-GREEN)		
H4P	LIGHT EMITTING DIODE (DEFROST-ORANGE)		
DS1	SELECTOR SWITCH (MAIN/SUB)		
DS2	SELECTOR SWITCH (WIRELESS ADDRESS SET)		
BS1	PUSH BUTTON (ON/OFF)		

- NOTES:**
- : TERMINAL BLOCK ○ : CONNECTOR --- : FIELD WIRING
 - IN CASE OF USING CENTRAL REMOTE CONTROLLER, CONNECT IT TO THE UNIT. IN ACCORDANCE WITH THE ATTACHED INSTALLATION MANUAL.
 - X24A, X33A, X35A, X39 ARE CONNECTED WHEN THE OPTIONAL ACCESSORIES ARE BEING USED.
 - FOR CHANGE OVER OF BR1E TYPE MAIN/SUB REFER TO MANUAL ATTACHED TO REMOTE CONTROLLER.
 - SYMBOLS SHOW AS FOLLOW: RED-RED BLK-BLACK WHT-WHITE YLW-YELLOW GRN-GREEN ORG-ORANGE BRN-BROWN PNK-PINK GRY-GRAY BLU-BLUE
 - SHOW ONLY IN CASE OF PROTECTED PIPES. USE H07RN-F IN CASE OF NO PROTECTION.
 - FOR DETAIL, SEE WIRING DIAGRAM ATTACHED TO OUTDOOR UNIT.
 - WHEN CONNECTING THE INPUT WIRES FROM OUTSIDE, FORCED OFF OR ON/OFF CONTROL OPERATION CAN BE SELECTED BY THE REMOTE CONTROLLER. SEE MANUAL FOR DETAIL.

3D109449-1B

9 Sound data

9 - 1 Sound Pressure Spectrum

FDXM25-35F9

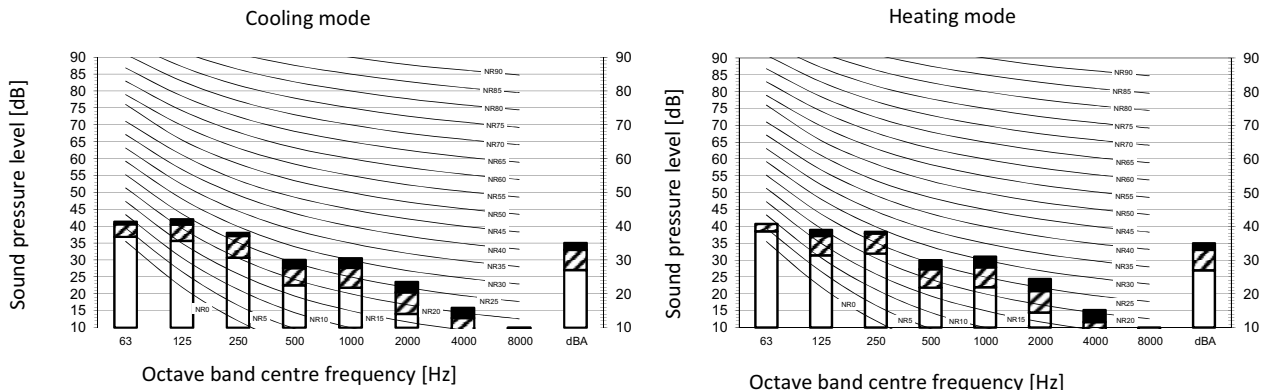

Legend

dBA = A-weighted sound pressure level (A scale according to IEC).

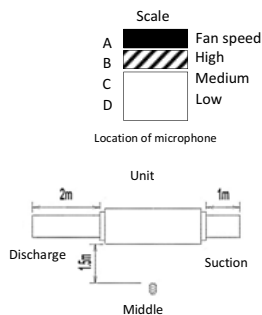

Cooling				Heating			
Total dB				Total dB			
A	B	C	D	A	B	C	D
dBA	35,0	33,0	27,0	dBA	35,0	33,0	27,0

Notes

- 1 . Operating conditions: power source 220-240V 50Hz; JIS standard
- 2 . Background noise already taken into account.
- 3 . Operating noise varies depending on operation and ambient conditions.
- 4 . The operation noise measuring method is in accordance with JISC9612.
- 5 . Measuring location: anechoic chamber

3D110007A

FTXM50F9

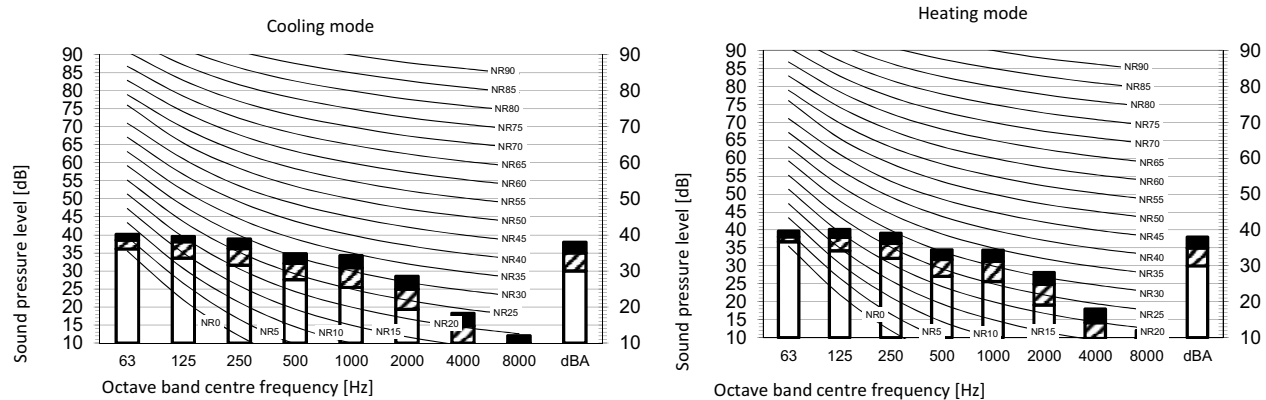

Legend

dBA = A-weighted sound pressure level (A scale according to IEC).

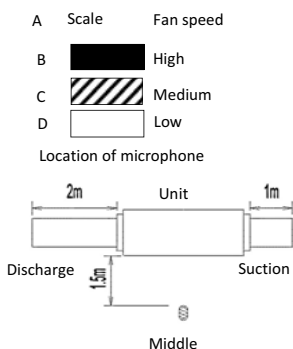

Cooling				Heating			
Total dB				Total dB			
A	B	C	D	A	B	C	D
dBA	38,0	35,0	30,0	dBA	38,0	35,0	30,0

Notes

- 1 . Operating conditions: power source 220-240V 50Hz; JIS standard
- 2 . Background noise already taken into account.
- 3 . Operating noise varies depending on operation and ambient conditions.
- 4 . The operation noise measuring method is in accordance with JISC9612.
- 5 . Measuring location: anechoic chamber

3D110009A

9 Sound data

9 - 1 Sound Pressure Spectrum

FDXM60F9

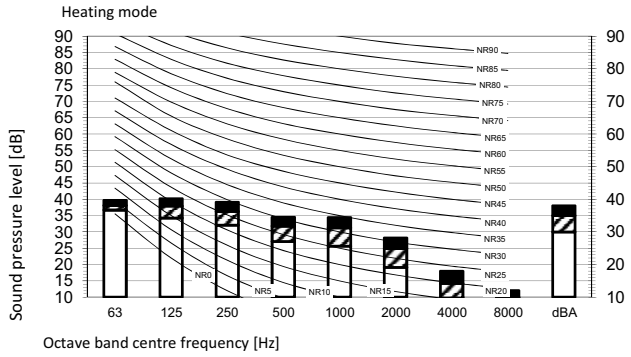
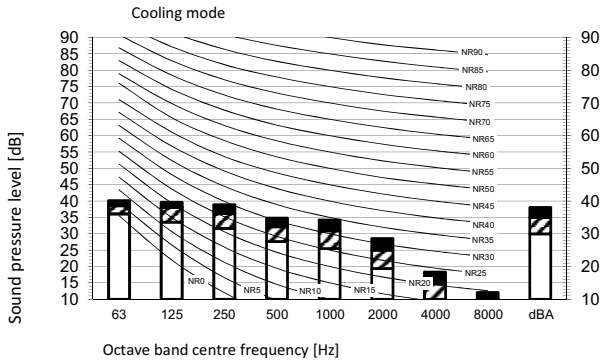

Legend
 dBA = A-weighted sound pressure level
 (A scale according to IEC).

Scale Fan speed
 A High
 B Medium
 C Low
 D

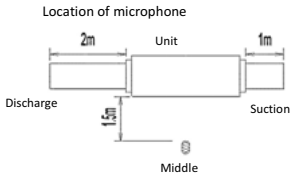

Cooling				Heating			
Total dB				Total dB			
A	B	C	D	A	B	C	D
dBA	38,0	35,0	30,0	dBA	38,0	35,0	30,0

Notes

- 1 . Operating conditions: power source 220-240V 50Hz; JIS standard
- 2 . Background noise already taken into account.
- 3 . Operating noise varies depending on operation and ambient conditions.
- 4 . The operation noise measuring method is in accordance with JISC9612.
- 5 . Measuring location: anechoic chamber

3D110010A

10 Fan characteristics

10 - 1 Fan Characteristics

10

FDXM25-35F9

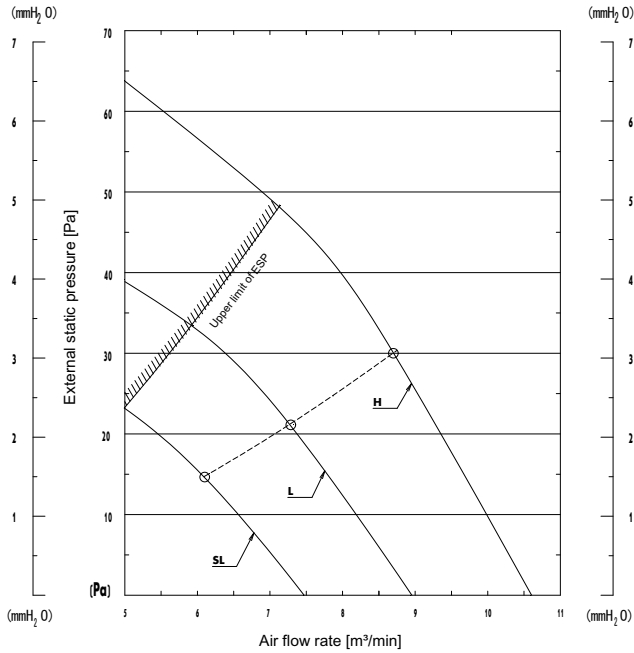

3D081327C

FDXM50F9

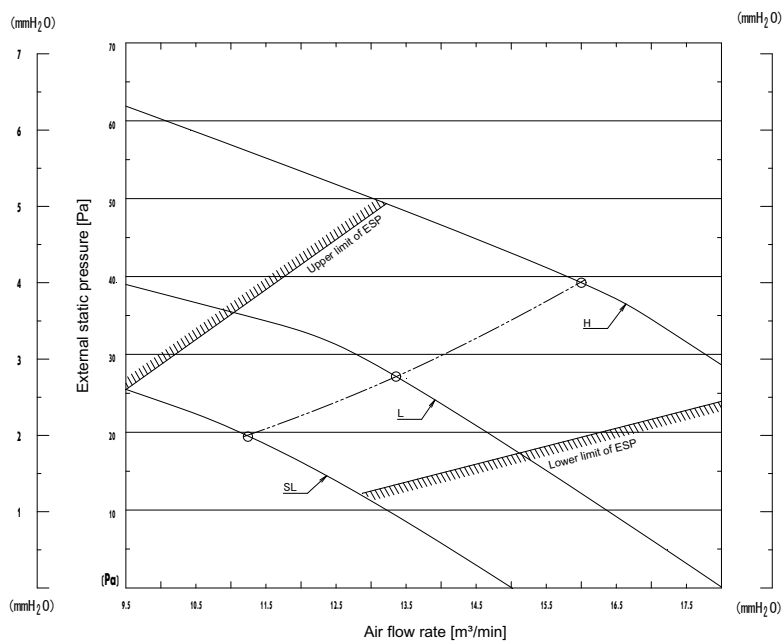

3D085960C

10 Fan characteristics

10 - 1 Fan Characteristics

FDXM60F9

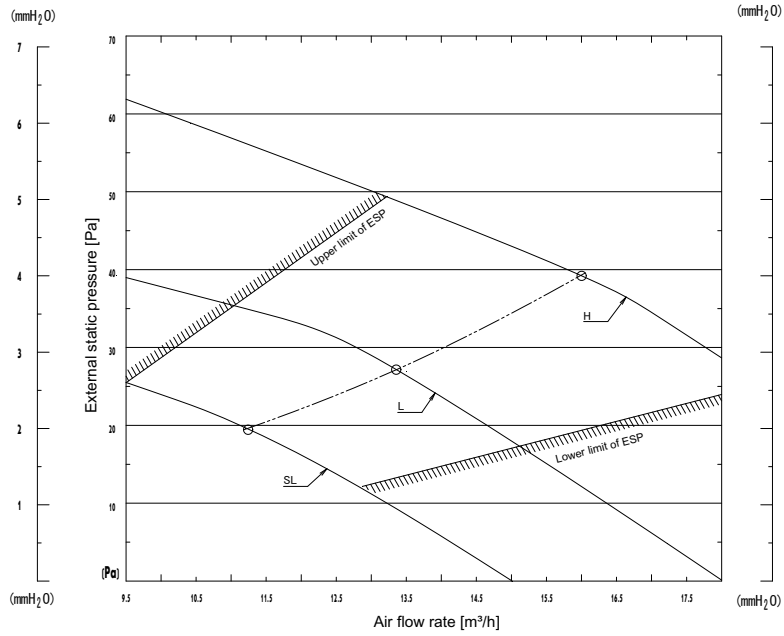

3D081329C



Daikin Europe N.V. Naamloze Vennootschap - Zandvoordestraat 300, B-8400 Oostende - Belgium - www.daikin.eu - BE 0412 120 336 - RPR Oostende

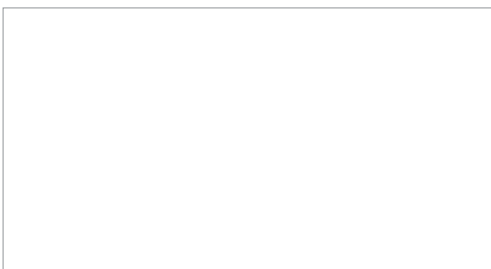

EEDEN19 10/18



Daikin Europe N.V. participates in the Eurovent Certified Performance programme for Liquid Chilling Packages and Hydronic Heat Pumps, Fan Coil Units and Variable Refrigerant Flow systems. Check ongoing validity of certificate: www.eurovent-certification.com



The present leaflet is drawn up by way of information only and does not constitute an offer binding upon Daikin Europe N.V.. Daikin Europe N.V. has compiled the content of this leaflet to the best of its knowledge. No express or implied warranty is given for the completeness, accuracy, reliability or fitness for particular purpose of its content and the products and services presented therein. Specifications are subject to change without prior notice. Daikin Europe N.V. explicitly rejects any liability for any direct or indirect damage, in the broadest sense, arising from or related to the use and/or interpretation of this leaflet. All content is copyrighted by Daikin Europe N.V.